

# Mathematical Modelling and Predictive Control of Permanent Magnet Synchronous Motor Drives

Květoslav Belda

Dept. of Adaptive Systems, Institute of Information Theory and Automation of the ASCR  
Pod Vodárenskou věží 4, 182 08 Prague 8, Czech Republic, e-mail: [belda@utia.cas.cz](mailto:belda@utia.cas.cz)

**Abstract**—The paper deals with a mathematical modelling of the three-phase Permanent Magnet Synchronous Motors (PMSM) and their model-based control. These motors are used in drives of robots and machine tools. The construction of their mathematical model is discussed here with respect to a model-based control design. The model is composed via mathematical-physical analysis. The analysis is outlined in the main theoretical points. As a promising model-based approach, the predictive control is explained. It represents just a promising alternative to the standard solution based on the vector cascade control.

**Keywords**—Permanent magnet synchronous motor, mathematical modelling, discrete predictive control, multistep explicit control law, square-root optimization.

## I. INTRODUCTION

Synchronous motors with a three-phase stator winding and a rotor with permanent magnets (Alternate Current – AC motors) belong to the latest generation of motors. They are applied as drives to machine tools and robots. Unlike Direct Current (DC) /brushes/ motors and Electrically Commuted (EC) /DC brushless/ motors, the Permanent Magnet Synchronous Motors (PMSM) (Fig. 1) may be configured as linear motors, which nowadays come in use in robotic applications as well.

The motors work on the principle of simultaneous control of amplitude and frequency of all three terminal harmonic currents with the Pulse-Width-Modulation (PWM). The stator of a three-phase AC motor represents three sinusoidally distributed windings with axes displaced by  $120^\circ$ . When the windings are excited by balanced three-phase sinusoidal currents, the combined effect is equivalent to a single sinusoidally distributed winding excited by a constant current and rotating at the stator frequency. The rotor magnetic field is supplied by permanent magnets instead of electromagnets [6].

In this paper, the mathematical modelling of the PMSM drives will be explained respecting a specific model-based control design. Construction of the model will arise from the mathematical physical analysis and will be shown in standard component forms and complex plane or space in different coordinate systems simplified control design.

From the control point of view, there are three main tasks: position control, speed control and current (torque) control. The tasks are closely related to a control configuration or control loops. An outer loop is the position loop, a middle loop is the speed loop and an internal loop is the current loop.

This paper will focus on the speed control task, which will be studied in the illustrative examples. Consequently, the speed and current loops will be investigated.

The task will be discussed for the conventional control approach based on the vector control with a cascade of PI controllers and for an advanced control approach based on the Generalized Predictive Control (GPC) [1], [4], [6].

The cascade configuration means set of autonomous PI controllers, where mutual relations are external disturbances. The setting of PI controllers is limited only on several static constants. Their fixed configuration does not give any space for some possible improvements or e.g. modifications solving further control requirements. On the other hand, the GPC is investigated as a general, simple flexible alternative, which can solve both speed and current loops together with the space for solution of additional requirements on the control.

The paper is organized as follows. The section II deals with a suitable mathematical-physical model for the control design. The section III discusses the model modification and related assumptions for the predictive control design. The section IV briefly describes the conventional loop schema of the vector control. The section V concerns with the main points of the GPC design. In the section, there is a derivation of equations of the predictions and explanation of the square-root minimizing procedure of the quadratic criterion. The generation of control actions as a result of the minimization is discussed. The section VI demonstrates the behaviour of the conventional vector control and the model predictive control by a comparative example.

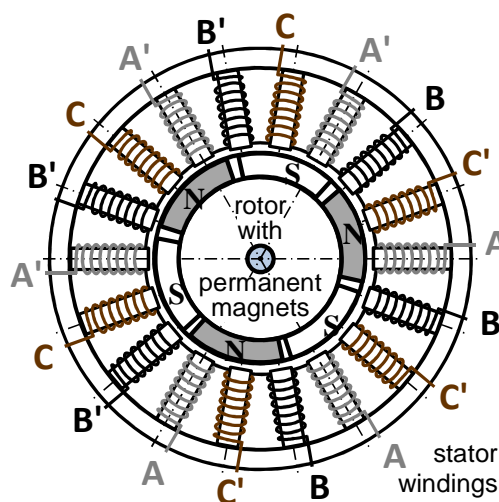

Fig. 1. Schematic cross section of PM Synchronous Motor with pole pair number  $p = 3$  and pole number  $pp = 6 (= 2p)$

## II. CONTROL-ORIENTED MODEL OF PMSM DRIVES

Mathematical-physical model of the PMSM drives is important both for the outline of the conventional vector control [3], [6] and mainly for the model-based control approaches in general. The model serves as a simulation model for rapid prototyping of the controllers. The model of permanent magnet synchronous motors arises from several natural laws and relations. Note, that the focus is given on the stator part of the motor, where the electric winding (coils) are built in. From the rotor point of view, only knowledge of magnetic properties of permanent magnets is necessary.

### A. Used Notation

The model covers the relations of the current and voltage equilibrium and appropriate relations of the voltage distribution for individual phases of the three-phase system. The model contains a number of parameters. Their notation and appropriate units are given as follows:

- $R_s$  - stator resistance [ $\Omega$ , Ohm]
- $L_s$  - stator inductance (surface PM) [H, Henry]
- $\psi_M$  - rotor magnetic flux [Wb, Weber]
- $p$  - number of pole pairs,  $pp = 2p$  - pole number
- $B$  - viscous coefficient of the load [ $\text{kg m}^2 \text{s}^{-1}$ ]
- $J$  - moment of load inertia [ $\text{kg m}^2$ ]
- $I_s$  - supply current [A]
- $U_s$  - supply voltage [V]
- $i_{SA}, i_{SB}, i_{SC}$  - currents of individual phases A, B, C [A]
- $u_{SA}, u_{SB}, u_{SC}$  - voltages of individual phases A, B, C [V]
- $i_{s\alpha}, i_{s\beta}$  - currents in the  $\alpha - \beta$  system [A]
- $u_{s\alpha}, u_{s\beta}$  - voltages in the  $\alpha - \beta$  system [V]
- $i_{sd}, i_{sq}$  - currents in the  $d - q$  system [A]
- $u_{sd}, u_{sq}$  - voltages in the  $d - q$  system [V]
- $n_m, f_m$  - mechanical speed [rpm], frequency [ $\text{Hz}; \text{s}^{-1}$ ]
- $n_e, f_e$  - electrical speed [ $\text{rpm}_e$ ], frequency [ $\text{Hz}_e; \text{s}_e^{-1}$ ]
- $\omega_m$  - mechanical angular speed [ $\text{rad s}^{-1}$ ]
- $\omega_e$  - electrical angular speed [ $\text{rad}_e \text{s}^{-1}$ ]
- $\vartheta_m$  - mechanical angle position [rad]
- $\vartheta_e$  - electrical angle position [ $\text{rad}_e$ ]
- $\tau_M$  - motor driving torque [Nm]
- $\tau_L$  - load torque [Nm]

### B. Initial Physical Description

Let the system of the equations describing the physical basis of the PMSM begin by an equation of stator current equilibrium:

$$i_{SA} + i_{SB} + i_{SC} = 0 \quad (1)$$

and analogously by an equation of stator voltage equilibrium:

$$u_{SA} + u_{SB} + u_{SC} = 0 \quad (2)$$

Further crucial relation is the stator voltage distribution expressed by a set of the following equations:

$$u_{SA} = R_s i_{SA} + \frac{d}{dt} \psi_{SA} \quad u_{SA} = R_s i_{SA} + \frac{d}{dt} (L_s i_{SA} + \psi_{MA}) \quad (3)$$

$$u_{SB} = R_s i_{SB} + \frac{d}{dt} \psi_{SB} \rightarrow u_{SB} = R_s i_{SB} + \frac{d}{dt} (L_s i_{SB} + \psi_{MB}) \quad (4)$$

$$u_{SC} = R_s i_{SC} + \frac{d}{dt} \psi_{SC} \quad u_{SC} = R_s i_{SC} + \frac{d}{dt} (L_s i_{SC} + \psi_{MC}) \quad (5)$$

where each line belongs to the appropriate individual phase. The equations (1) - (5) express the electro-magnetic properties of the stator coil winding (Fig. 2).

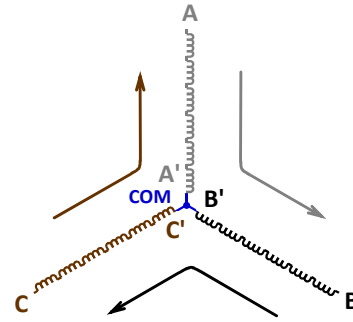

Fig. 2. Pole permanent magnet field windings for 6 poles

The mathematical model in the two-dimensional (2D) space of the three-phase A-B-C system is completed by the relation of electro-mechanical properties expressed by the equation of the torque equilibrium:

$$\begin{aligned} J \ddot{\vartheta}_M &= \sum_i \tau_i \rightarrow J \dot{\omega}_M = \tau_M - B \omega_M - \tau_L \\ &\rightarrow J \dot{\omega}_e = p \tau_M - B \omega_e - p \tau_L \end{aligned} \quad (6)$$

where  $\tau_M$  is a motor (driving) torque given by

$$\tau_M = \frac{p}{\omega_e} \left\{ \frac{3}{2} \text{Re}\{U_s I_s\} - 3R_s I_s^2 \right\} \quad (7)$$

$B \omega_M$  is a mechanical loss and  $\tau_L$  is a load torque. All these quantities follow from the law of the energy conservation:

$$\begin{aligned} P_{el, \text{ power input}} &= P_{mech, \text{ load}} + P_{coil \text{ losses}} + P_{losses \text{ in iron (mag.)}} + P_{mech, \text{ losses}} \\ \frac{3}{2} \text{Re}\{U_s I_s\} &= \tau_L \omega_m + 3R_s I_s^2 + P_{Fe} + B \omega_m^2 \end{aligned} \quad (8)$$

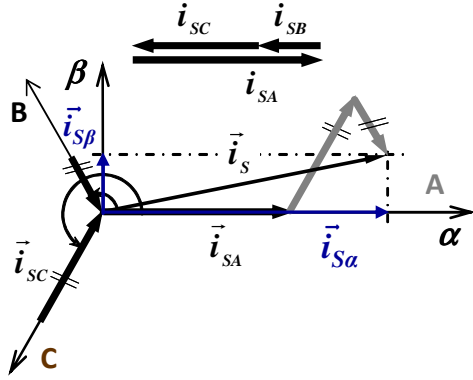
 Fig. 3. 2D A-B-C and  $\alpha$ - $\beta$  coordinate systems

### C. Simplifying Transformations

The equations (1) - (6) constitute the initial model representation in the fixed 2D three-phase system for individual A, B, C phases. That model can be simplified both for the simulation and control design by two specific transformations.

The first is forward Clarke transformation (Fig. 3):

$$\begin{bmatrix} i_{s\alpha} \\ i_{s\beta} \end{bmatrix} = k \begin{bmatrix} 1 & -\frac{1}{2} & -\frac{1}{2} \\ 0 & \frac{\sqrt{3}}{2} & -\frac{\sqrt{3}}{2} \end{bmatrix} \begin{bmatrix} i_{sA} \\ i_{sB} \\ i_{sC} \end{bmatrix}, \quad k = \frac{2}{3} \quad (9)$$

Considering the current equilibrium (1), then the transformation can be reduced as follows

$$\begin{bmatrix} i_{s\alpha} \\ i_{s\beta} \end{bmatrix} = k \begin{bmatrix} \frac{3}{2} & 0 \\ \frac{\sqrt{3}}{2} & \sqrt{3} \end{bmatrix} \begin{bmatrix} i_{sA} \\ i_{sB} \end{bmatrix}, \quad k = \frac{2}{3} \quad (10)$$

This transformation converts (3) - (6) from the 2D A-B-C phase system into the 2D  $\alpha$ - $\beta$  system. The indicated transforming procedure is valid for both current, voltage and flux components considering appropriate physical quantities respectively. It represents reduction of three phases or three appropriate phase axes in only two  $\alpha$ - $\beta$  axes. The axes are fixed to the stator coordinate system i.e. to the initial A-B-C phase system.

The transformed equations are expressed as follows:

$$u_{s\alpha} = R_s i_{s\alpha} + L_s \frac{d}{dt} i_{s\alpha} - \psi_M \sin(\vartheta_e) \dot{\vartheta}_e \quad (11)$$

$$u_{s\beta} = R_s i_{s\beta} + L_s \frac{d}{dt} i_{s\beta} + \psi_M \cos(\vartheta_e) \dot{\vartheta}_e \quad (12)$$

$$J \ddot{\vartheta}_e = \frac{3}{2} p^2 \psi_M (\cos \vartheta_e i_{s\beta} - \sin \vartheta_e i_{s\alpha}) - B \omega_e - p \tau_L \quad (13)$$

The second transformation is the forward Park transformation shown in Fig. 4:

$$\begin{bmatrix} i_{sd} \\ i_{sq} \end{bmatrix} = \begin{bmatrix} \cos \vartheta_e & \sin \vartheta_e \\ -\sin \vartheta_e & \cos \vartheta_e \end{bmatrix} \begin{bmatrix} i_{s\alpha} \\ i_{s\beta} \end{bmatrix} \quad (14)$$

That transformation converts the 2D  $\alpha$ - $\beta$  system (11) - (13) into the 2D  $d$ - $q$  system. The  $d$ - $q$  system unlike the two fixed  $\alpha$ - $\beta$  axes system is constituted by two rotating  $d$ - $q$  axes.

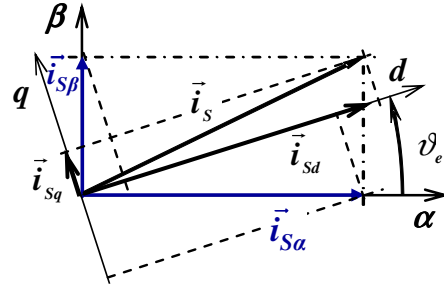
 Fig. 4. 2D  $\alpha$ - $\beta$  and  $d$ - $q$  coordinate systems

The axes are connected to the rotating electromagnetic field of the stator coil winding or rotating rotor with permanent magnets. The AC PMSM is a synchronous motor as it is mentioned directly in its label. Thus, the speed of the electromagnetic rotating field is equal to the speed of the rotor and proportionally synchronous with the input current frequency.

The equations (11) - (13) applying (14) get the forms:

$$u_{sd} = R_s i_{sd} + L_s \frac{d}{dt} i_{sd} - L_s \omega_e i_{sq} \quad (15)$$

$$u_{sq} = R_s i_{sq} + L_s \frac{d}{dt} i_{sq} + L_s \omega_e i_{sd} + \psi_M \omega_e \quad (16)$$

$$J \ddot{\vartheta}_e = \frac{3}{2} p^2 \psi_M i_{sq} - B \omega_e - p \tau_L \quad (17)$$

### D. Derivation of the Transformations in Complex Space

The indicated transformations in the previous subsection can be derived also in a more compact form in the complex space. If the initial equations (1) - (5) are considered, then the Clarke transformation is defined by means of complex variable as follows:

$$u_s = u_{sA} + u_{sB} e^{j\frac{2}{3}\pi} + u_{sC} e^{j\frac{4}{3}\pi} = u_{s\alpha} + j u_{s\beta} \quad (18)$$

using representation of complex variable as

$$e^{j\varphi} = \cos \varphi + j \sin \varphi \quad (19)$$

then

$$u_s = \underbrace{R_s i_{s\alpha} + \frac{d}{dt} (L_s i_{s\alpha} + \psi_{M\alpha})}_{u_{s\alpha}} + j \underbrace{(R_s i_{s\beta} + \frac{d}{dt} (L_s i_{s\beta} + \psi_{M\beta}))}_{u_{s\beta}} \quad (20)$$

with  $\psi_{M\alpha} = \psi_M \cos \vartheta_e$ ,  $\psi_{M\beta} = \psi_M \sin \vartheta_e$

leads identically to the equations (11) and (12).

Analogically, the same situation is at the Park transformation. Let the derivation start from the equations (1) - (5) again. Then, from the geometrical point of view, the equations finalized by the Park transformation with natural inclusion of the Clarke transformation are the following:

$$\begin{aligned} u_s e^{-j\vartheta_e} &= u_{sA} e^{-j\vartheta_e} + u_{sB} e^{j\frac{2}{3}\pi} e^{-j\vartheta_e} + u_{sC} e^{j\frac{4}{3}\pi} e^{-j\vartheta_e} \\ &= u_{s\alpha} e^{-j\vartheta_e} + j u_{s\beta} e^{-j\vartheta_e} \\ &= u_{sd} + j u_{sq} \end{aligned} \quad (21)$$

with  $e^{-j\vartheta_e} = \cos \vartheta_e - j \sin \vartheta_e$  (22)

Then, the indicated expression leads to the form (23)

$$u_s e^{-j\theta} = \underbrace{R_s i_{sd} + L_s \frac{d}{dt} i_{sd} - L_s \omega_e i_{sq}}_{u_{sd}} + j \underbrace{(R_s i_{sq} + L_s \frac{d}{dt} i_{sq} + \psi_M \omega_e + L_s \omega_e i_{sd})}_{u_{sq}} \quad (23)$$

which gives identical equations for  $u_{sd}$  and  $u_{sq}$  defined by the equations (15) and (16).

Note, the symbol  $u_s$  in the explanation above represents the resultant necessary input stator voltage supplied by a power supply.

### E. Resulting Mathematical Model of PMSM drive

The resultant mathematical model consists of two first order differential equations in the current point of view in the rotating reference frame and one second order differential equation in the rotation angle (angular position of the rotating reference frame) point of view:

$$u_{sd} = R_s i_{sd} + L_s \frac{d}{dt} i_{sd} - L_s \omega_e i_{sq} \quad (24)$$

$$u_{sq} = R_s i_{sq} + L_s \frac{d}{dt} i_{sq} + L_s \omega_e i_{sd} + \psi_M \omega_e \quad (25)$$

$$J \ddot{\vartheta}_e = \frac{3}{2} p^2 \psi_M i_{sq} - B \omega_e - p \tau_L \quad (26)$$

The  $d$ - $q$  model (24) - (26) can be expressed just in the appropriate state-space like form (27):

$$\frac{d}{dt} \begin{bmatrix} i_{sd} \\ i_{sq} \\ \omega_e \\ \tau_L \end{bmatrix} = \begin{bmatrix} -\frac{R_s}{L_s} & 0 & 0 & 0 \\ 0 & -\frac{R_s}{L_s} & -\frac{\psi_M}{L_s} & 0 \\ 0 & \frac{3}{2} \frac{p^2}{J} \psi_M & -\frac{B}{J} & -\frac{p}{J} \\ 0 & 0 & 0 & 0 \end{bmatrix} \begin{bmatrix} i_{sd} \\ i_{sq} \\ \omega_e \\ \tau_L \end{bmatrix} + \begin{bmatrix} \omega_e i_{sq} \\ -\omega_e i_{sd} \\ 0 \\ 0 \end{bmatrix} + \begin{bmatrix} \frac{1}{L_s} & 0 \\ 0 & \frac{1}{L_s} \\ 0 & 0 \\ 0 & 0 \end{bmatrix} \begin{bmatrix} u_{sd} \\ u_{sq} \end{bmatrix} \quad (27)$$

This model form represents as simple as possible the mathematical-physical description suitable for simulation and simple basis for the model-based control design.

The model (27) contains nonlinear elements. They will be discussed in section III. According to the indicated model forms and corresponding transformations in this section, the usual industrial control, i.e. the cascade PI control, is structured as well. The brief description of the cascade control will be given in the section IV.

Finally, for further explanation, the full state vector  $[i_{sd}, i_{sq}, \omega_e, \tau_L]^T$  is assumed to be known from measured variables ( $[i_{SA(BC)}, \omega_e, \tau_L]^T$ ) including also the angular position  $\vartheta_e$ . The angular position  $\vartheta_e$  is not included into the state vector due to direct relation to the angular speed:

$$\frac{d}{dt} \vartheta_e = \omega_e \quad (28)$$

### III. MODEL MODIFICATION AND ASSUMPTIONS FOR MODEL-BASED CONTROL DESIGN

As was mentioned, the suitable model for the model-based control design is a model in the  $d$ - $q$  coordinate system (27). In spite of its simplicity, it contains two nonlinear terms. Thus, for the model based control, the model (27) has to be linearized, so that the predictive control, a multistep approach, can be realized. The nonlinear terms may be linearized as follows:

$$\begin{bmatrix} \omega_e i_{sq} \\ -\omega_e i_{sd} \\ 0 \\ 0 \end{bmatrix} = \begin{bmatrix} 0 & \omega_e & 0 & 0 \\ -\omega_e & 0 & 0 & 0 \\ 0 & 0 & 0 & 0 \\ 0 & 0 & 0 & 0 \end{bmatrix} \begin{bmatrix} i_{sd} \\ i_{sq} \\ \omega_e \\ \tau_L \end{bmatrix} \quad (29)$$

if the reference state variables are selected to be zeros

$$i_{sdr} = 0, i_{sqr} = 0, \omega_{er} = 0, \tau_{Lr} = 0 \quad (30)$$

The linearization or linearizing decomposition (29) arises from the following idea [8] and specific reference state:

$$\mathbf{f}(x, y, z) = \frac{\mathbf{f}(x_r, y_r, z) - \mathbf{f}(x_r, y_r, z_r)}{(x - x_r)} (x - x_r) + \frac{\mathbf{f}(x_r, y_r, z) - \mathbf{f}(x_r, y_r, z_r)}{(y - y_r)} (y - y_r) + \frac{\mathbf{f}(x_r, y_r, z) - \mathbf{f}(x_r, y_r, z_r)}{(z - z_r)} (z - z_r) \quad (31)$$

if  $\mathbf{f}(x_r, y_r, z_r) = \mathbf{0}$

Then, the resulting linearized form is:

$$\frac{d}{dt} \begin{bmatrix} i_{sd} \\ i_{sq} \\ \omega_e \\ \tau_L \end{bmatrix} = \begin{bmatrix} -\frac{R_s}{L_s} & \omega_e & 0 & 0 \\ -\omega_e & -\frac{R_s}{L_s} & -\frac{\psi_M}{L_s} & 0 \\ 0 & \frac{3}{2} \frac{p^2}{J} \psi_M & -\frac{B}{J} & -\frac{p}{J} \\ 0 & 0 & 0 & 0 \end{bmatrix} \begin{bmatrix} i_{sd} \\ i_{sq} \\ \omega_e \\ \tau_L \end{bmatrix} + \begin{bmatrix} \frac{1}{L_s} & 0 \\ 0 & \frac{1}{L_s} \\ 0 & 0 \\ 0 & 0 \end{bmatrix} \begin{bmatrix} u_{sd} \\ u_{sq} \end{bmatrix} \quad (32)$$

This model form represents already the usual state-space model, but with time-variant terms:

$$\frac{d\mathbf{x}(t)}{dt} = \mathbf{A}_c(t) \mathbf{x}(t) + \mathbf{B}_c \mathbf{u}(t) \quad (33)$$

$\mathbf{A}_c(t)$  is a time-variant state-space matrix,  $\mathbf{B}_c$  is a constant input matrix. The variances of  $\mathbf{A}_c(t)$  are given by the variable  $\omega_e$  elements, i.e.  $\mathbf{A}_c(t) = \mathbf{A}_c(\omega_e(t))$ .

The model (32), as against (27), can be already discretized by the standard exponential discretization procedure to the form:

$$\mathbf{x}_{k+1} = \mathbf{A}_k \mathbf{x}_k + \mathbf{B}_k \mathbf{u}_k \quad (34)$$

$$\mathbf{y}_k = \mathbf{C}_k \mathbf{x}_k \quad (35)$$

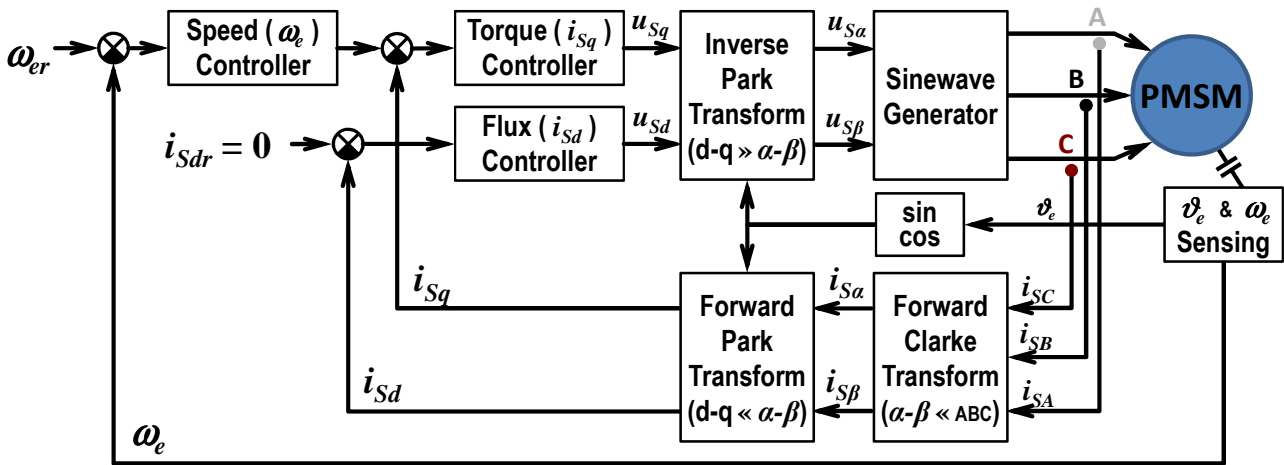

Fig. 5. Speed control of PMSM by vector control (two-step cascade control)

IV. USUAL CASCADE PI CONTROL

As was mentioned, the usual industrial control, i.e. the cascade PI control, follows the directly described way in section II. After measurement of individual phase currents and measurement or estimation rotor position and rotor speed the currents are transformed stepwise by the forward Clarke transformation and by the forward Park transformation into the  $d-q$  coordinate system. In it, the main control operation is executed. The designed control actions ( $d-q$  voltages) are converted via the inverse Park transformation back to the  $\alpha-\beta$  system ( $\alpha-\beta$  voltages). The control actions in the  $\alpha-\beta$  system are led to the Sinewave generator, which generates appropriate individual voltage magnitudes for individual A-B-C phases. It is illustrated in Fig. 5.

That schema of the PSMS speed control consists of two interconnected loops. The main (master) loop is a speed loop. The subsidiary (slave) loop is a current loop realized as two parallel legs corresponding to the torque and flux control respectively. Each loop or leg contains an isolated PI controller. From the control theory point of view, this arrangement represents at least six control parameters (gains, time constants), which are usually empirically or by simple auto-tuning algorithm set up [9].

In specific cases, the PI control is supplemented by a field weakening to reach the high speed region, due to increasing the Electro Magnetic Field voltage and finite supply voltage [10]. The field weakening is done by the current  $d$ - component, which produces a magnetic flux opposite to the permanent magnet flux, see Fig. 6. Note that the output of the current controller (current component in the  $q$  axis) must be limited according to the rising current component in the  $d$  axis with respect to maximum allowed value of the current magnitude.

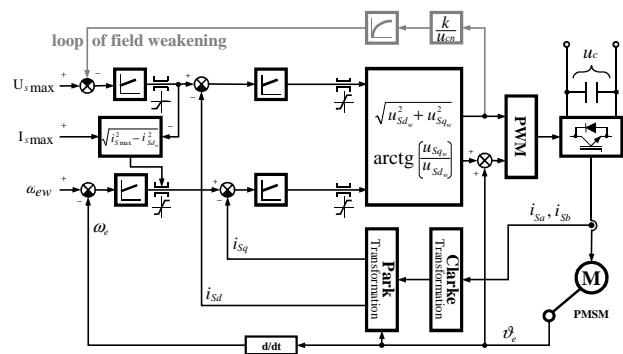

Fig. 6. Speed control of PMSM with field weakening loop.

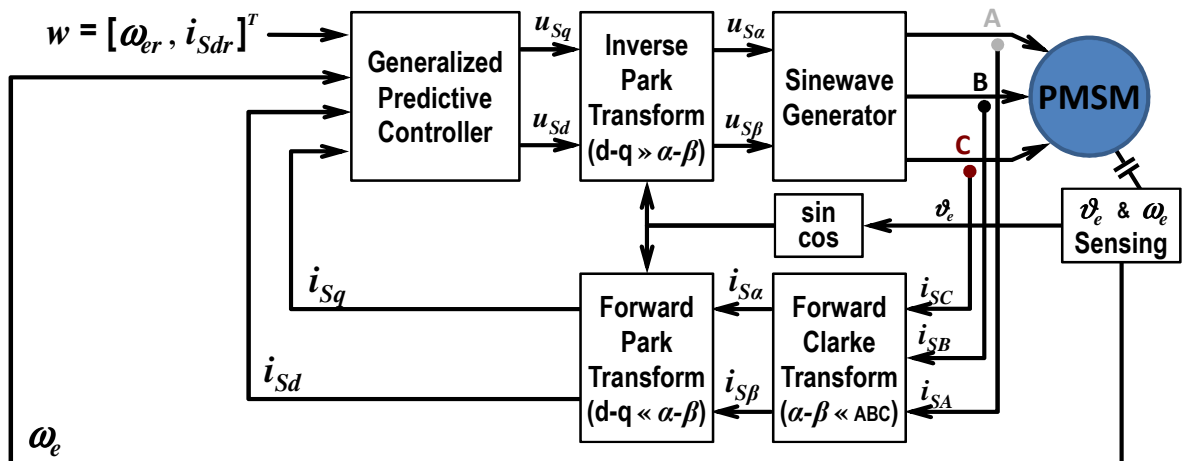

Fig. 7. Speed control of PMSM by Generalized Predictive Control

## V. PREDICTIVE CONTROL

The Predictive Control is a flexible and powerful control approach [11]. Its illustrative schema for an application to the speed control of the PMSM drives is in Fig. 7. The basis of the Predictive control is a minimization of a quadratic criterion (36), in which the future system outputs are substituted by their predictions (37) expressed by the model given by (34) and (35) [1], [2]:

$$\min_{\mathbf{u}} J = \min_{\mathbf{u}} \mathbf{J}^T \mathbf{J} = \min_{\mathbf{u}} [\|\mathbf{Q}_y(\hat{\mathbf{y}} - \mathbf{w})\|^2 + \|\mathbf{Q}_u \mathbf{u}\|^2] \quad (36)$$

$$\hat{\mathbf{y}} = \mathbf{f} + \mathbf{G}\mathbf{u}, \mathbf{f} = \begin{bmatrix} \mathbf{C}\mathbf{A}_k \\ \vdots \\ \mathbf{C}\mathbf{A}_k^N \end{bmatrix} \mathbf{x}_k, \mathbf{G} = \begin{bmatrix} \mathbf{C}\mathbf{B} & \cdots & \mathbf{0} \\ \vdots & \ddots & \vdots \\ \mathbf{C}\mathbf{A}_k^{N-1}\mathbf{B} & \cdots & \mathbf{C}\mathbf{B} \end{bmatrix} \quad (37)$$

where  $\hat{\mathbf{y}}$ ,  $\mathbf{w}$  and  $\mathbf{u}$  are vectors of the predictions (future predicted system outputs), references and control actions (system inputs) for a given prediction horizon  $N$ :  $\hat{\mathbf{y}} = [\hat{\mathbf{y}}_{k+1}, \dots, \hat{\mathbf{y}}_{k+N}]^T$ ,  $\mathbf{w} = [\mathbf{w}_{k+1}, \dots, \mathbf{w}_{k+N}]^T$ ,  $\mathbf{u} = [\mathbf{u}_k, \dots, \mathbf{u}_{k+N-1}]^T$  and  $\mathbf{Q}_y$  and  $\mathbf{Q}_u$  are the weighting control parameters: output and input matrix penalizations. The predictions  $\hat{\mathbf{y}}_{k+1}, \dots, \hat{\mathbf{y}}_{k+N}$  in appropriate time instants of the prediction horizon can be expressed recurrently by the model equations (34) and (35) according to the formula (37).

The forms of the quadratic cost function as well as equations of the predictions depend on control requirements given by user or considered application [4], [10], [11].

The minimization of the criterion (36) can be provided by several ways. The powerful one is a way via a solution based on the least squares [7] applied to the algebraic equation system:

$$\mathbf{J} = \begin{bmatrix} \mathbf{Q}_y & \mathbf{0} \\ \mathbf{0} & \mathbf{Q}_u \end{bmatrix} \begin{bmatrix} \hat{\mathbf{y}} - \mathbf{w} \\ \mathbf{u} \end{bmatrix} = \underbrace{\begin{bmatrix} \mathbf{Q}_y \mathbf{G} \\ \mathbf{Q}_u \end{bmatrix}}_{\mathbf{A}} \mathbf{u} - \underbrace{\begin{bmatrix} \mathbf{Q}_y(\mathbf{w} - \mathbf{f}) \\ \mathbf{0} \end{bmatrix}}_{\mathbf{b}} \quad (38)$$

$$\begin{aligned} \mathbf{J} &\rightarrow \min \Rightarrow \mathbf{A} \mathbf{u} - \mathbf{b} = \mathbf{0} \\ \mathbf{A} \mathbf{u} &= \mathbf{b} \quad / \mathbf{Q}^T \\ \mathbf{Q}^T \mathbf{A} \mathbf{u} &= \mathbf{Q}^T \mathbf{b} \end{aligned} \quad (39)$$

where  $\mathbf{Q}$  is an orthogonal matrix, which rearranged the matrix  $\mathbf{A}$  into the upper right triangle matrix  $\mathbf{R}$  or  $\mathbf{R}_1$  respectively as it is indicated:

$$\mathbf{R} \mathbf{u} = \mathbf{c} \quad (40)$$

$$\begin{array}{ccc} \boxed{\mathbf{A}} \begin{array}{|c|} \hline \mathbf{u} \\ \hline \end{array} = \begin{array}{|c|} \hline \mathbf{b} \\ \hline \end{array} & \Rightarrow & \begin{array}{|c|} \hline \mathbf{R}_1 \\ \hline \mathbf{0} \end{array} \begin{array}{|c|} \hline \mathbf{u} \\ \hline \end{array} = \begin{array}{|c|} \hline \mathbf{c}_1 \\ \hline \mathbf{c}_2 \end{array} \end{array} \quad (41)$$

The vector  $\mathbf{c}_2$  is a lost vector, whose Euclidean norm  $\|\mathbf{c}_2\|$  is equal value of the square root  $\sqrt{J}$  (i.e.  $J = \mathbf{c}_2^T \mathbf{c}_2$ ). To obtain unknown control actions  $\mathbf{u}$ , only the upper part of the system (41) is used for final control determination as follows.

$$\begin{aligned} \mathbf{R}_1 \mathbf{u} &= \mathbf{c}_1 \\ \mathbf{u} &= (\mathbf{R}_1)^T \mathbf{c}_1 \end{aligned} \quad (42)$$

Since a matrix  $\mathbf{R}_1$  is upper triangle, then the control  $\mathbf{u}$  is given directly by the back-run procedure. The indicated way represents a pure solution, which can be reached on-line.

Different, the most related optimization way at the GPC is a quadratic programming, i.e. optimization of the objective function (43) by algorithms of the quadratic programming [4]:

$$\begin{aligned} \min_{\mathbf{u}} \mathbf{F}(\mathbf{u}) &= \min_{\mathbf{u}} \left\{ \frac{1}{2} \mathbf{u}^T \underbrace{(\mathbf{G}^T \mathbf{Q}_y \mathbf{G} + \mathbf{Q}_u)}_{\mathbf{H}} \mathbf{u} + \underbrace{(\mathbf{f} - \mathbf{w})^T \mathbf{G}}_{\mathbf{g}^T} \mathbf{u} \right\} \\ &= \min_{\mathbf{u}} \left\{ \frac{1}{2} \mathbf{u}^T \mathbf{H} \mathbf{u} + \mathbf{g}^T \mathbf{u} \right\}, \quad \mathbf{A} \mathbf{u} \leq \mathbf{b} \end{aligned} \quad (43)$$

The quadratic programming can solve equality and inequality constrains as it is indicated in (43). However, for the PMSM drives, it is a quite time-consuming way apart from the pre-computed offline implementations [12]. Finally, the simplest way, possibly tailored for fast dynamic systems as the PMSM drive are, is a direct search of local minimum of the quadratic cost function (quadratic criterion). This way can lead to explicit forms of control laws, which can be for the PMSM drives pre-computed off-line. Then, during the real-time (on-line) control, control actions are determined by selection of an appropriate control law corresponding to the topical state of the system. In case of the PMSM drive control, the selected parameter or state variable is angular velocity (see model (32)). The described way leads to the following computation form

$$\mathbf{u} = (\mathbf{G}^T \mathbf{Q}_y \mathbf{G} + \mathbf{Q}_u)^{-1} \mathbf{G}^T \mathbf{Q}_y (\mathbf{w} - \mathbf{f}) \quad (44)$$

and corresponding explicit control law of the constant velocity-dependent gains:

$$\mathbf{u}_k = \mathbf{k}_w \mathbf{w}_k - \mathbf{k}_x \mathbf{x}_k \quad (45)$$

## VI. COMPARATIVE EXAMPLE

In this section, there is a brief description of one comparative example of the data from a real experiment and data obtained by simulation. The real experiment was realized on the Siemens PMSM drive with the type designation: 1FK7022-5AK-1LG0 [9].

In Fig. 8, there is time history of the real measured data from the real experiment. In Fig. 9, there is time history of the simulation data. The comparative simulation is provided by the mathematical model from section II. The model parameters of the PMSM drive were taken from a manual [9] for the motor mentioned above.

The figures show similar courses of the corresponding time histories of physical quantities: mechanical speed  $\omega_m$ , phase voltages  $u_{SA(BC)}$  and phase currents  $i_{SA(BC)}$ . The obvious smoothness of the simulation is caused by considering the motor as ideal system without any disturbance. The both experiments run for a triangular profile of the desired rotational speed values within the interval  $\pm 100$ rpm. The condition on zero (minimum) currents was included both in the real experiment and simulation.



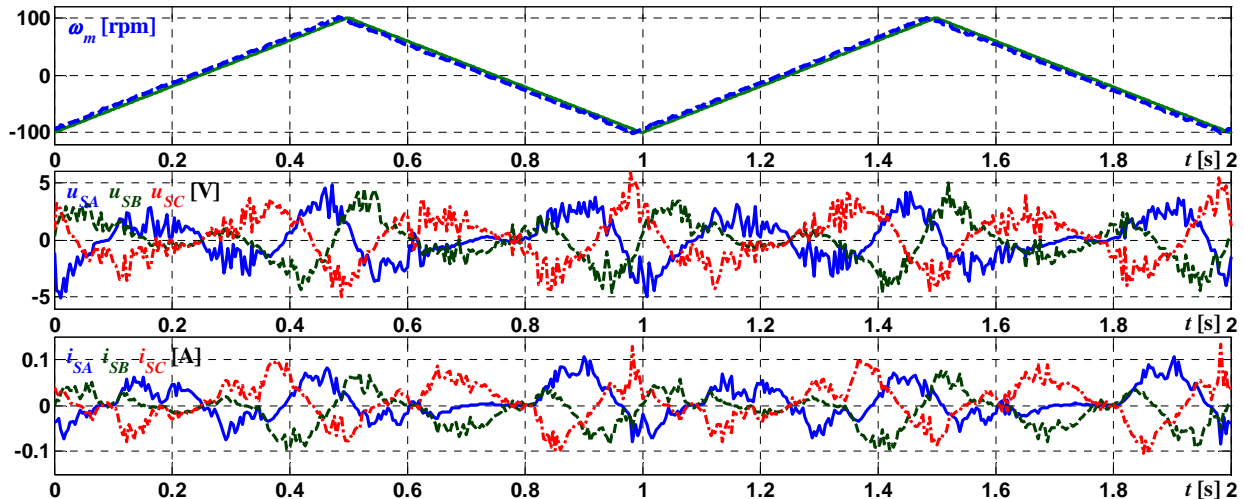

Fig. 8. Speed control of PMSM by two-step cascade PI control – time histories of real experiment, sampling period  $T_s = 0.000125s$

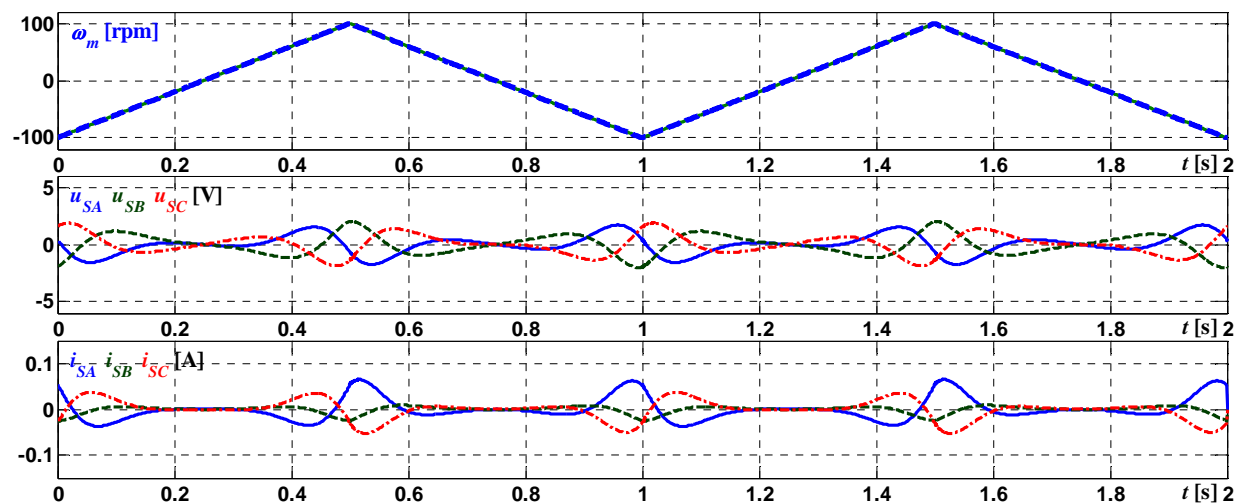

Fig. 9. Speed control of PMSM by Generalized Predictive Control – time histories of simulation; horizon  $N = 8$ , sampling period  $T_s = 0.000125s$

## VII. CONCLUSION

The paper deals with a study of the Predictive Control design for the PMSM drives. Their mathematical model was explained and used in the model-based control design. The industrial cascade PI control was briefly explained as well. The comparative example demonstrates the similarity of the industrial realization and model-based design. The Predictive Control is a promising way to optimize the drive control with a possibility to consider other requirements or drive constraints, which cannot be simply solved by conventional control systems.

## REFERENCES

- [1] A. Ordys, D. Clarke, "A state - space description for GPC controllers". *Int. J. Systems Sci.*, Vol. 24, No. 9, 1993, pp. 1727-1744.
- [2] K. Belda, J. Böhm, P. Píša, "Concepts of Model-Based Control and Trajectory Planning for Parallel Robots". Proc. of 13th IASTED Int. Conf. on Robotics and Applications. Germany. 2007, pp. 15-20.
- [3] L. Prokop, P. Grasblum, "3-Phase PMSM Vector Control: Design of Motor Control Application", Freescale Semiconductor, 2005.
- [4] K. Belda, D. Vošmik, "Speed Control of PMSM Drives by Generalized Pred. Algorithms". *IECON Proc.*, 2012, pp. 2002-2007.
- [5] E. Santana, E. Bim, W. Amamral, "A Predictive Alg. for Controlling Speed and Rotor Flux of Induction Motor". *IEEE Trans. on industrial electronics*, Vol. 55, No. 12, 2008, pp. 4398-4407.
- [6] S. Bolognani, L. Peretti, M. Zigliotto, "Design and Implementation of MPC for EMD". *IEEE Trans. on IE*, 56/6, 2009, pp. 1925-1936.
- [7] Ch. Lawson, R. Hanson, "Solving Least Square Problems", Prentice-Hall, Inc., New York, 1974.
- [8] M. Valášek, P. Steinbauer, "Nonlinear Control of Multibody Systems", *Euromech*, Lisbon, 1999, pp. 437-444.
- [9] SINAMICS S110 / S120, "Synchronous motors 1FK7, Generation 2", Configuration Manual 10/2011, 6SN1197-0AD16-0BP4.
- [10] K. Belda, D. Vošmik, "Explicit Generalized Predictive Algorithms for Speed Control of PMSM Drives". *IECON*, Austria, 2013, 6 pp.
- [11] L. Wang, *Model Predictive Control System Design and Implementation Using MATLAB*, Springer, 2009.
- [12] M. Kvasnica, J. Löfberg, M. Herceg, L. Cirka, and M. Fikar, "Low complexity polynomial approximation of explicit MPC via linear programming," *AC Control Conference* 2010, pp. 4713-4718.

The author appreciates kind support of the Grant Agency of the Czech Republic by the grant No. GP102/11/0437 'Control and Parameter Identification of AC Electric Drives under Critical Operating Conditions'.